

Pulse Generators and Pulse Amplifiers for MCP Image Intensifiers MCP-PROXIFIER®



Pulse Generator IG 5N

Introduction

To assure the safe operation of gateable MCP image intensifiers MCP-PROXIFIER® with 25 mm and 40 mm useful diameter, PROXITRONIC offers pulse generators and pulse amplifiers. Gating is accomplished by switching the photocathode voltage between -180 V (on) and +12 V (off) for 100 ns, or between -180 V (on) and +80 V (off) for 5 ns, respectively 10 ns, depending on the shortest pulse duration demanded. The following versions are available:

- The **Pulse Generators IP** are designed for the gateable 25 mm and 40 mm MCP image intensifier types **BV 256...N** and **BV 406...N** which do not have an integrated high voltage power supply.
- The **Pulse Generators IG** are designed for the gateable 25 mm and 40 mm MCP image intensifier types **BV 258...N** and **BV 408...N** which have an integrated high voltage power supply.
- The **Pulse Amplifiers IV** are designed for all gateable 25 mm and 40 mm MCP image intensifier types **BV 256...N**, **BV 258...N**, **BV 406...N**, and **BV 408...N**. Pulse amplifiers generate only the photocathode voltage according to external TTL trigger signals. If a pulse amplifier is operated together with a gateable MCP image intensifier BV 256...N or BV 406...N (which do not have an integrated power supply), the image intensifier will require an external power supply type PS 1015 Q00... to generate MCP and phosphor screen voltage.

Technical Data of Pulse Generators IP and IG

	IP 5N	IP 100N	IG 5N	IG 100N
For gateable image intensifiers	BV 256...N BV 406...N	BV 256...N BV 406...N	BV 258...N BV 408...N	BV 258...N BV 408...N
Shortest gating time	5 ns (BV 256...N) 10 ns (BV 406...N)	100ns (BV 256...N) 100ns (BV 406...N)	5 ns (BV 258...N) 10 ns (BV 408...N)	100ns (BV 258...N) 100ns (BV 408...N)
Longest internal preset gating time ¹	1 ms	1 ms	1 ms	1 ms
Photocathode voltage	-180 V (on) +80 V (off)	-180 V (on) +12 V (off)	-180 V (on off) +80 V (off)	-180 V (on) +12 V (off)
MCP input voltage	0 V	0 V	0 V	0 V
MCP output voltage for single MCP ²	+ 400 V ... + 800 V	+ 400 V ... + 800 V	No ³	No ³
MCP output voltage for double MCP ²	+ 1000 V ... + 1800 V	+ 1000 V ... + 1800 V	No ³	No ³
MCP output voltage for triple MCP ²	+ 1500 V ... + 2700 V	+ 1500 V ... + 2700 V	No ³	No ³
Phosphor screen voltage (reference to MCP output)	+ 6000 V	+ 6000 V	No ³	No ³
Supply voltage	12 V DC	12 V DC	12 V DC	12 V DC
Supply current ⁴	500 mA	200 mA	500 mA	200 mA
Trigger input	TTL (50 Ω)	TTL (50 Ω)	TTL (50 Ω)	TTL (50 Ω)
Maximum trigger frequency	200 Hz (2 kHz ⁵)	14 kHz (40 kHz ⁶)	200 Hz (2 kHz ⁵)	14 kHz (40 kHz ⁶)
Internal trigger delay ⁷	ca. 90 ns	ca. 150 ns	ca. 90 ns	ca. 150 ns
External trigger delay ⁷	ca. 60 ns	ca. 120 ns	ca. 60 ns	ca. 120 ns
Jitter	max. 1 ns	max. 1 ns	max. 1 ns	max. 1 ns
Rise time 10 % ... 90 %	2 ns (BV 256...N) 6 ns (BV 406...N)	10 ns (BV 256...N) 15 ns (BV 406...N)	2 ns (BV 258...N) 6 ns (BV 408...N)	10 ns (BV 258...N) 15 ns (BV 408...N)
Decay time 90 % ... 10 %	2 ns (BV 256...N) 6 ns (BV 406...N)	10 ns (BV 256...N) 15 ns (BV 406...N)	2 ns (BV 258...N) 6 ns (BV 408...N)	10 ns (BV 258...N) 15 ns (BV 408...N)
Maximum cable length to image intensifier ⁸	120 mm	300 mm	120 mm	300 mm
Demountable connection to image intensifier	No	No	Yes	Yes
Width	70 mm	70 mm	70 mm	70 mm
Height	70 mm	70 mm	70 mm	70 mm
Length	258 mm	258 mm	168 mm	168 mm
Housing	Aluminum black anodized	Aluminum black anodized	Aluminum black anodized	Aluminum black anodized
Weight	ca. 1300 g	ca. 1300 g	ca. 1100 g	ca. 1100 g

1. Longer preset internal gating times are possible for an extra charge. External TTL trigger signals can be of any period of time.
2. Adjustment by 10-turn potentiometer on the control panel on the rear of the housing.

3. Voltage generated by power supply integrated into the image intensifier.
4. Data given for a 1:1 pulse-duty factor and 20 ms pulse duration. For higher repetition rates, the power consumption increases.
5. 2 kHz possible for an extra charge.
6. 40 kHz possible for an extra charge.
7. Exact data is measured and documented for each pulse generator.
8. Longer cables are possible but lead to longer rise and decay times of the gate pulses.

If a gateable image intensifier is ordered together with a pulse generator, the image intensifier will be mounted inside a black anodized aluminum housing. On request, C-mount or photo lens mounts are possible.

An AC/DC adapter suitable for any public power supply system (input 90 V AC ... 264 V AC, output 12 V DC) is delivered together with the image intensifier and the pulse generator.

A TTL signal (50 Ω) must be supplied to the trigger input on the control panel of the pulse generator all the time during operation. The photocathode of the image intensifier opens on the rising flank of the TTL signal (see section "Pulse Diagrams"). At position 8 and 9 of the pulse width selector, the pulse durations follow the course of the external TTL signal. At positions 0 to 7, the image intensifier is gated with the preset internal pulse widths. In both cases, external and internal triggering, the pulse repetition rate is always the frequency of the external TTL signal.

Control Panel of Pulse Generators IG and IP

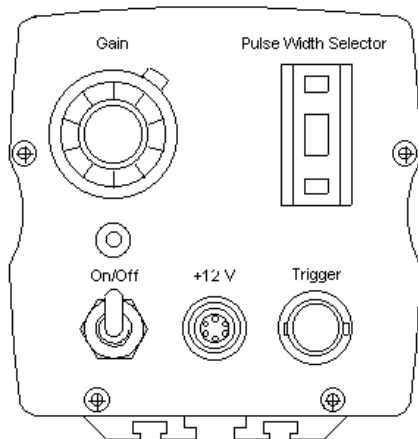

Pulse Width Selector

- Positions 0 to 7: 8 fixed internal pulse widths to be defined by the customer when the pulse generator is ordered.
- Positions 8 and 9: the photocathode voltage follows the course of the external TTL trigger signal.

Gain Adjustment

The adjustment of the gain of the image intensifier is done by a 10-turn potentiometer. The MCP voltage rises linearly with the potentiometer setting.

Technical Drawing Pulse Generator IP

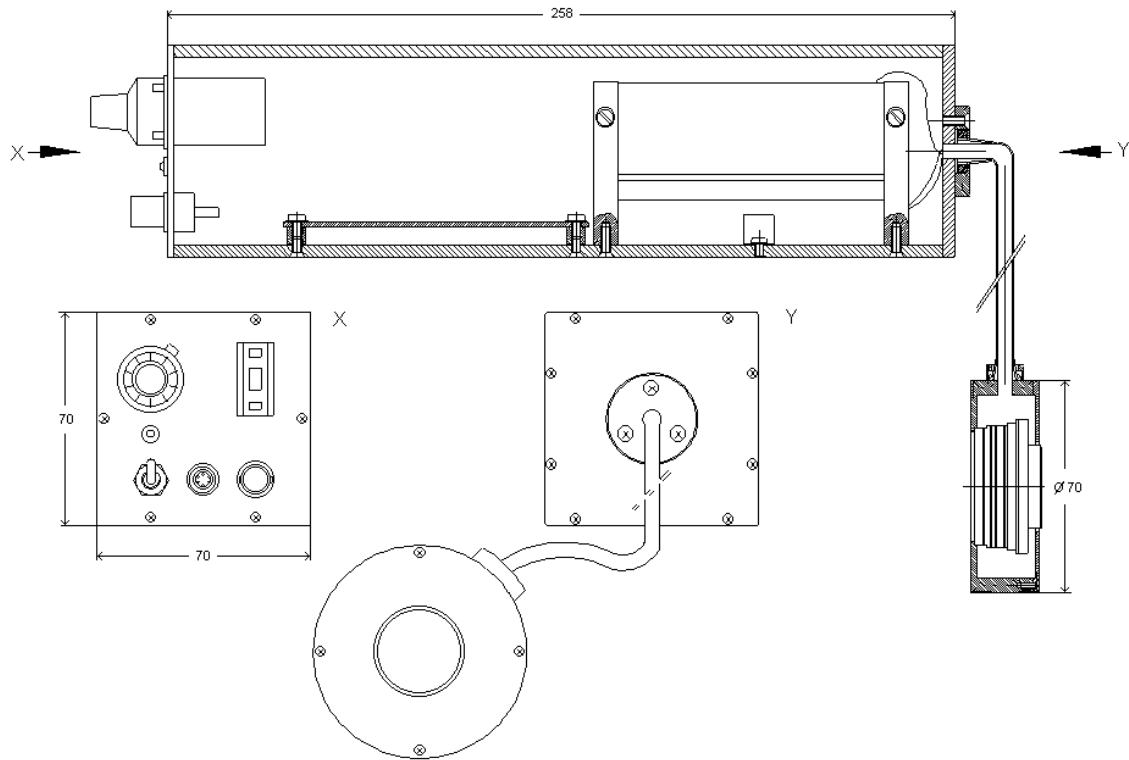

Technical Drawing Pulse Generator IG

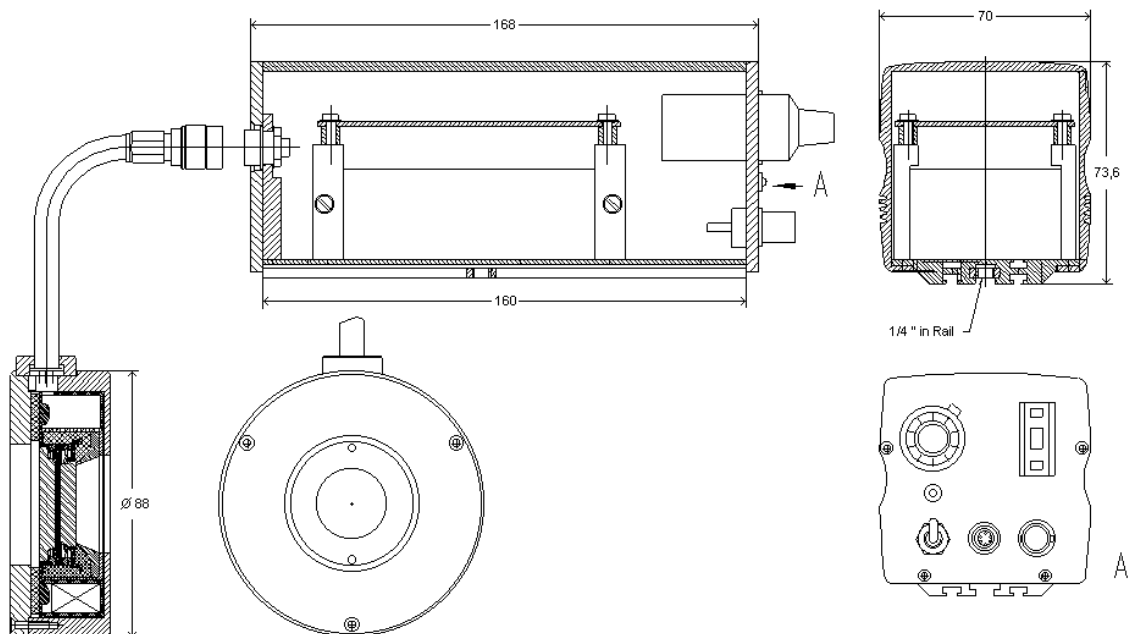

Technical Data of Pulse Amplifier IV

	IV 5N	IV 100N
For gateable image intensifiers	BV 256...N BV 406...N	BV 256...N BV 406...N
Shortest gating time	5 ns (BV 25...N) 10 ns (BV 40...N)	100 ns (BV 25...N) 100 ns (BV 40...N)
Photocathode voltage	-180 V (on) +80 V (off)	-180 V (on) +12 V (off)
MCP input voltage	0 V	0 V
MCP output voltage	No ¹	No ¹
Phosphor screen voltage	No ¹	No ¹
Supply voltage	12 V DC	12 V DC
Supply current ²	70 mA	35 mA
Trigger input	TTL (1 k Ω)	TTL (1 k Ω)
Maximum trigger frequency	200 Hz (2 kHz ³)	14 kHz (40 kHz ⁴)
Delay for external trigger ⁵	ca. 30 ns	ca. 90 ns
Jitter	max. 1 ns	max. 1 ns
Rise time 10 % ... 90 %	2 ns (BV 25...N) 6 ns (BV 40...N)	10 ns (BV 25...N) 15 ns (BV 40...N)
Decay time 90 % ... 10 %	2 ns (BV 25...N) 6 ns (BV 40...N)	10 ns (BV 25...N) 15 ns (BV 40...N)
Maximum cable length to image intensifier ⁶	120 mm	300 mm
Demountable connection to image intensifier	No	No
Width	50 mm	50 mm
Height	30 mm	30 mm
Length	100 mm	100 mm
Housing	Aluminum	Aluminum
Weight	ca. 180 g	ca. 180 g

1. Voltage has be generated by an additional internal or external power supply.
2. Data given for a 1:1 pulse-duty factor and 20 ms pulse duration. For higher repetition rates, the power consumption increases.
3. 2 kHz possible for an extra charge.
4. 40 kHz possible for an extra charge.
5. Exact data is measured and documented for each pulse amplifier.
6. Longer cables are possible but lead to longer rise and decay times of the gating pulses.

Technical Drawing of Pulse Amplifier IV

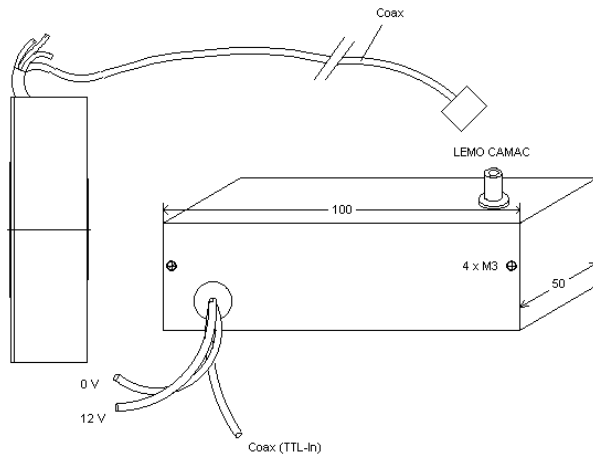

Inputs

- Red: + 12 V DC
- Black: 0 V
- TTL input: Coaxial cable RG 178

Output

- LEMO CAMAC socket FAA.00.250.NTA

Pulse Diagrams

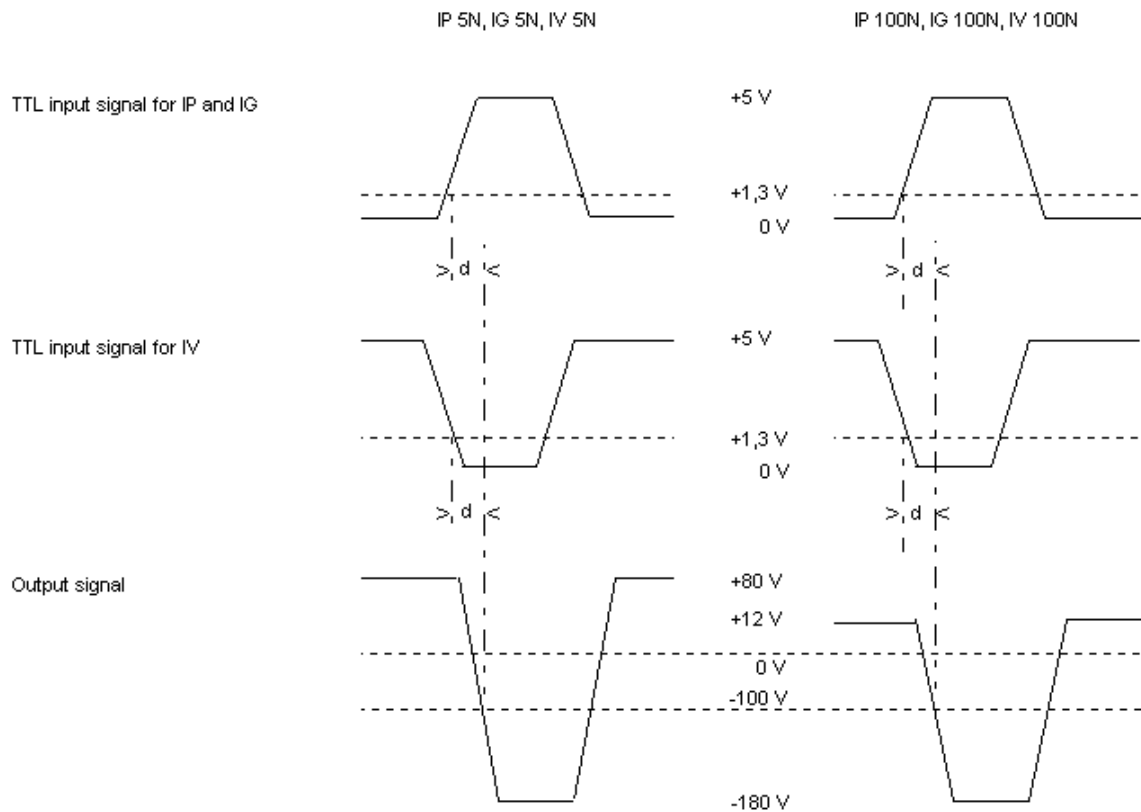

d = trigger delay