

High Power Laser Diode TO-Cans

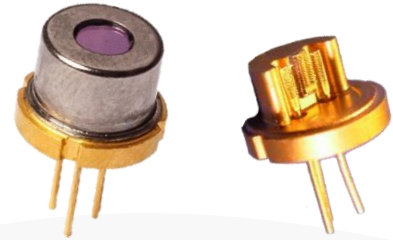

Part Number: TO9-105

High Power TO9 Package
Single-Mode Fabry-Perot
CW Wavelength at 1550nm
Lensed Options Available



Features

- High Output Power
- High Dynamic Range
- High Efficiency
- Standard TO9
- Cost Effective

Application

- Home Use Medical
- Laser Rangefinders
- Target Illumination
- Telecom OTDR



SemiNex delivers the highest available power at infrared wavelengths between 12xx and 19xx nm. When necessary, we will further optimize the design of our InP & GaSb laser chips to meet our customers' specific optical and electrical performance needs. Diodes, bars and packages are tested to meet customer and market performance demands. Typical results and packaging options are shown. Contact SemiNex for additional details or to discuss your specific requirements.

High Power Laser Diode TO-Cans



Specification

TO9-105

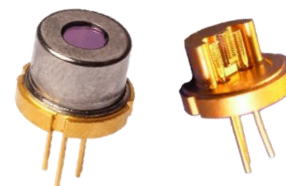

Optical	Symbol	Typ.	Units
Center Wavelength	λ_c	1550	nm (± 20)
Output Power (CW)*	P_{out}	0.4	watts ($\pm 10\%$)
Emitter Width	W	4	μm
Spectral Width FWHM	$\Delta\lambda$	10	nm
Slope Efficiency	η	0.3	W/A
Fast Axis Div.	θ_{\perp}	30	deg FWHM
Slow Axis Div.	θ_{\parallel}	10	deg FWHM
Electrical	Symbol		Units
Power Conversion Eff.	η	13	%
Threshold Current	I_{TH}	0.05	A
Operating Current	I_{op}	1.2	A
Operating Voltage	V_{op}	2.5	V
Mechanical	Symbol	Range	Units
Operating Temp.**		-40 to 60	$^{\circ}C$
Storage Temp.		-40 to 80	$^{\circ}C$

*Specified values are rated at a constant heat sink temperature of 20 $^{\circ}C$.

**High temperature operation will reduce performance and MTTF.
Unless otherwise indicated all values are nominal.

*Available Lenses & Caps

Suffix	Description
TO9-105	TO9 Uncapped
TO9-105-114	TO9 Cap, 4.6mm Tall
TO9-105-115	TO9 5.8mm Tall Cap, Lens Collimated <5mrad f=590 μm , 5mm lg
TO9-105-140	TO9 5.8mm Tall Cap, Lens Matched f=171 μm , 5.0 lg
TO9-105-161	TO9 Cap 5.8mm Tall

High Power Laser Diode TO-Cans



SemiNex Laser Diodes TO9-105 Graphs & Data



Typical TO9 L-I-V Characteristics

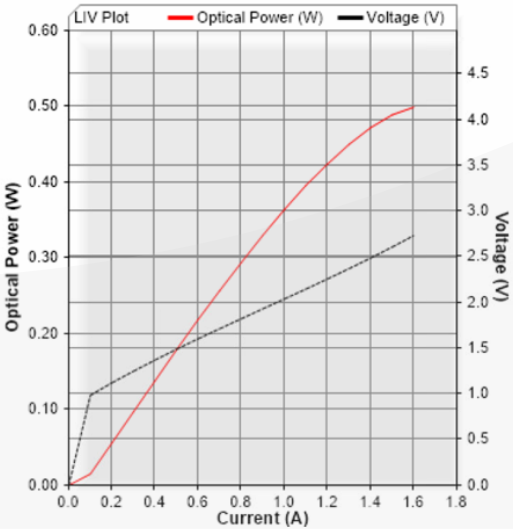

Typical TO9 Output Spectrum

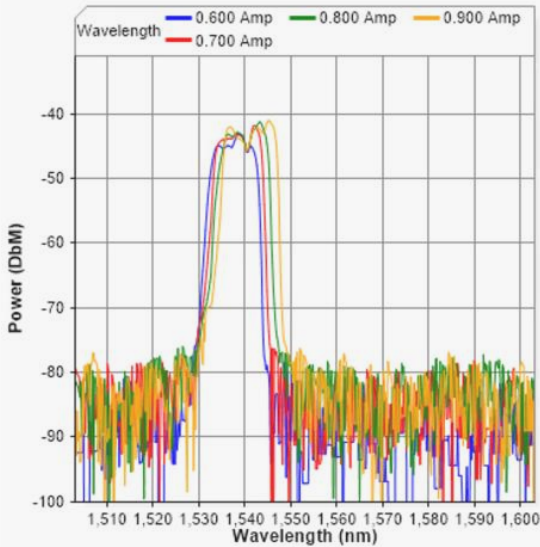

High Power Laser Diode TO-Cans



Mechanical Drawing TO9-105

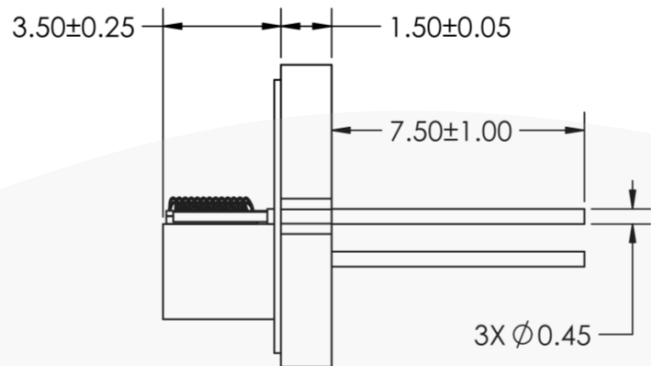
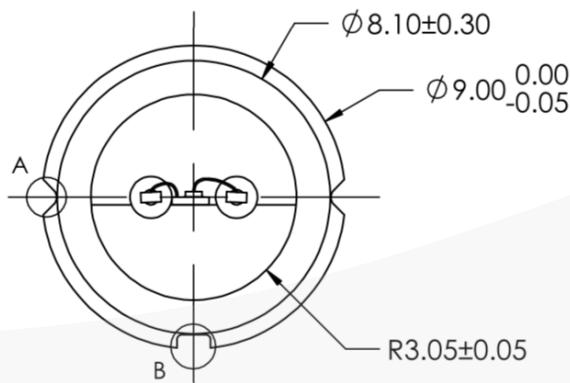

PIN OUT:

1. LD CATHODE (-)
2. CASE
3. LD ANODE (+)

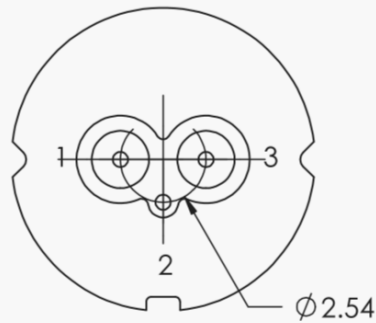

All statements, technical information and recommendations related to the product herein are based upon information believed to be reliable or accurate. The accuracy or completeness herein is not guaranteed, and no responsibility is assumed for any inaccuracies. The user assumes all risks and liability whatsoever in connection with the use of a product or its application. SemiNex Corporation reserves the right to change at any time without notice the design, specification, deduction, fit or form of its described herein, including withdrawal at any time of a product offered for sale herein. Users are encouraged to visit www.seminex.com for the latest data. SemiNex Corporation makes no representations that the products herein are free from any intellectual property claims of others. Please contact SemiNex for more information. 2024 SemiNex Corporation



High Power Laser Diode TO-Cans



Mechanical Drawing

TO9-105-115

TO9-105-140

TO9-105-161

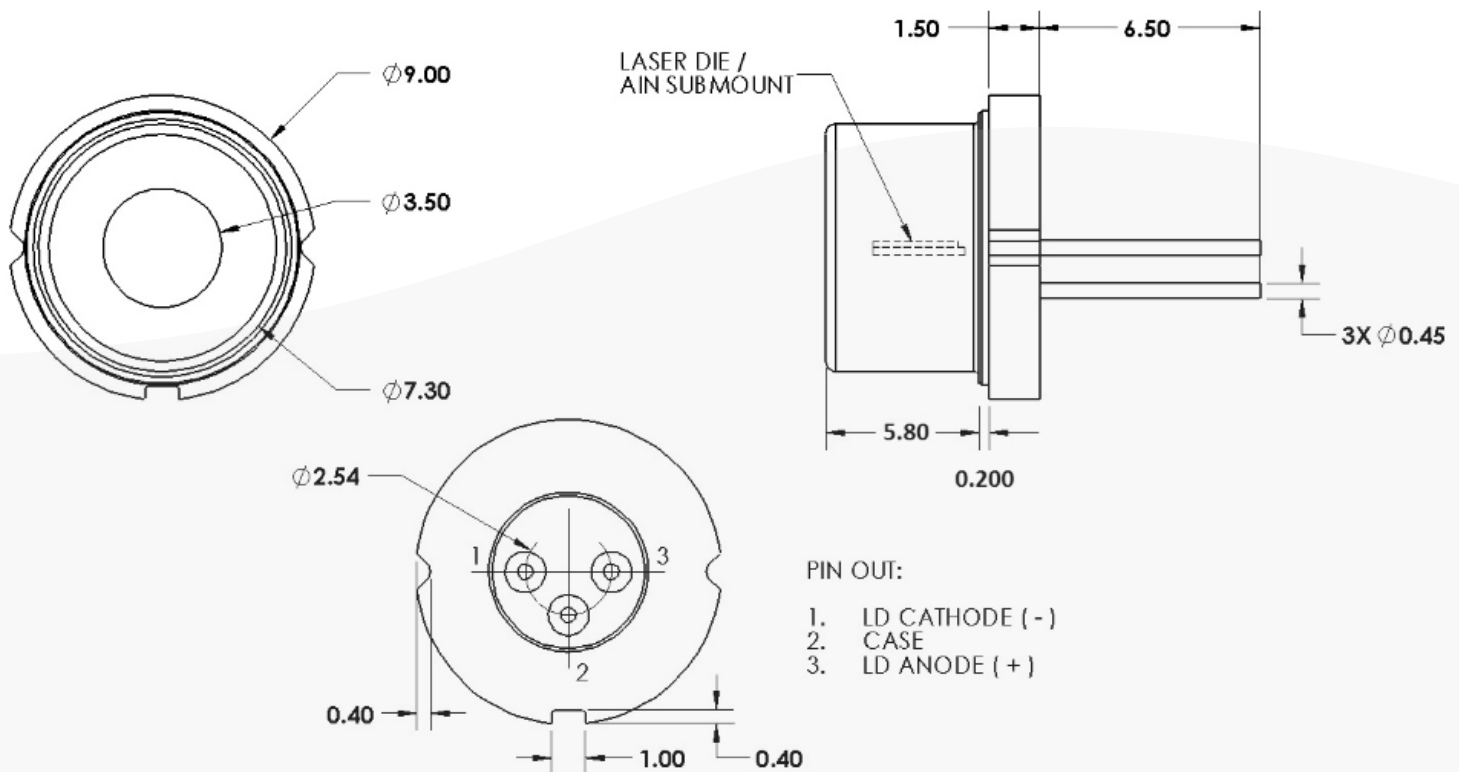
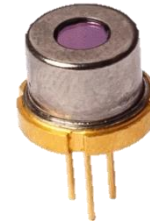

All statements, technical information and recommendations related to the product herein are based upon information believed to be reliable or accurate. The accuracy or completeness herein is not guaranteed, and no responsibility is assumed for any inaccuracies. The user assumes all risks and liability whatsoever in connection with the use of a product or its application. SemiNex Corporation reserves the right to change at any time without notice the design, specification, deduction, fit or form of its described herein, including withdrawal at any time of a product offered for sale herein. Users are encouraged to visit www.seminex.com for the latest data. SemiNex Corporation makes no representations that the products herein are free from any intellectual property claims of others. Please contact SemiNex for more information. 2024 SemiNex Corporation



SemiNex Corporation • 153 Andover Street, Suite 201, Danvers, MA 01923 • 978-326-7700 • sales@seminex.com

High Power Laser Diode TO-Cans



Mechanical Drawing TO9-105-114

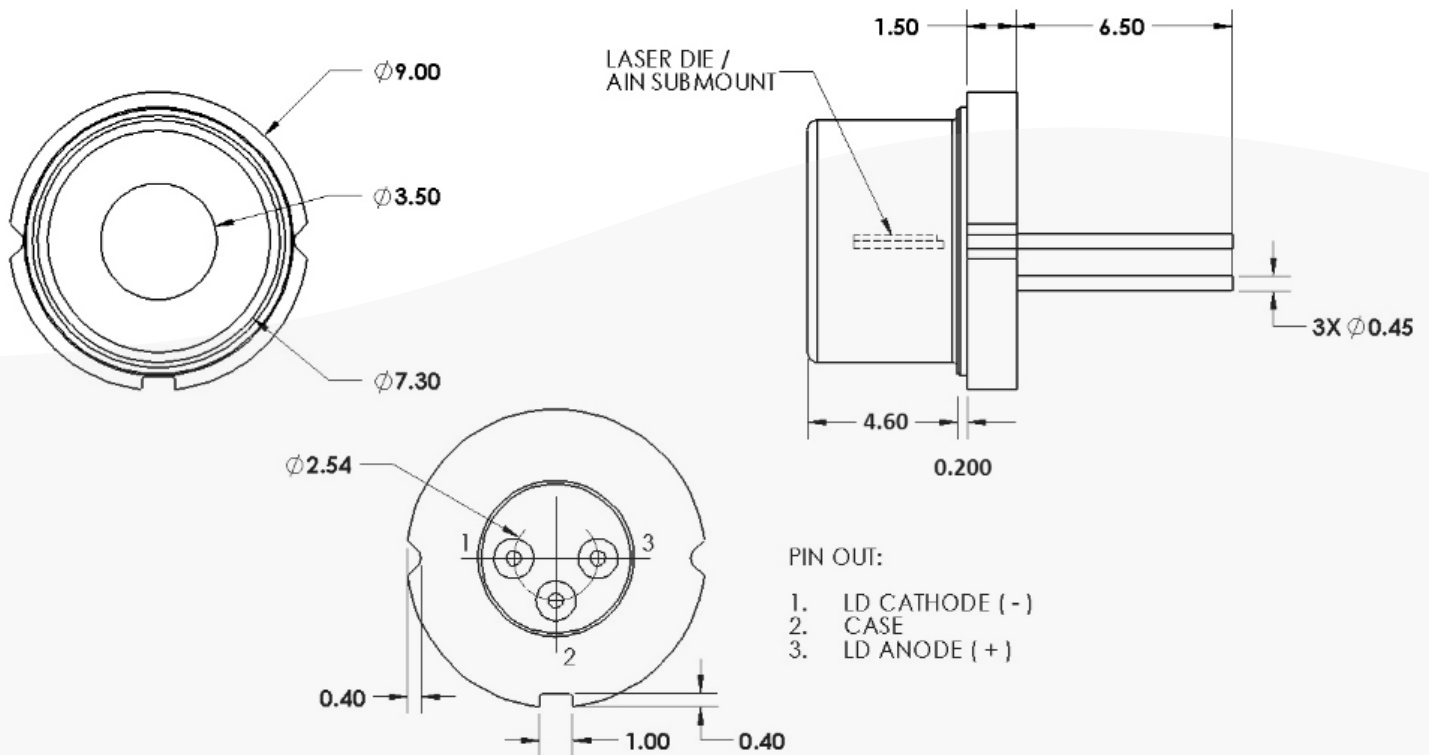

All statements, technical information and recommendations related to the product herein are based upon information believed to be reliable or accurate. The accuracy or completeness herein is not guaranteed, and no responsibility is assumed for any inaccuracies. The user assumes all risks and liability whatsoever in connection with the use of a product or its application. SemiNex Corporation reserves the right to change at any time without notice the design, specification, deduction, fit or form of its described herein, including withdrawal at any time of a product offered for sale herein. Users are encouraged to visit www.seminex.com for the latest data. SemiNex Corporation makes no representations that the products herein are free from any intellectual property claims of others. Please contact SemiNex for more information. 2024 SemiNex Corporation

SemiNex Corporation • 153 Andover Street, Suite 201, Danvers, MA 01923 • 978-326-7700 • sales@seminex.com

